

Excelon® Modular System

F72G, F73G, F74G General Purpose Filters

Excelon® design allows in-line or modular installation with other Excelon® products

Quick release bayonet bowl

Highly visible prismatic liquid level indicator lens on metal bowls

Technical data

Fluid:

Compressed air

Operating pressure:

Transparent bowl: 150 psig (10 bar)

Metal bowl: 250 psig (17 bar)

F72G w/metal bowl and automatic drain: 150 psig (10 bar)

Operating temperature*:

Transparent bowl: -30° to 125°F (-34° to 50°C)

Metal bowl:

(72) -30° to 150°F (-34° to 66°C)

(73, 74) -30° to 175°F (-34° to 80°C)

* Air supply must be dry enough to avoid ice formation at temperatures below 35°F (2°C).

Materials

F72G

Body: zinc

Transparent bowl: polycarbonate

Metal bowl: zinc

Metal bowl liquid level indicator lens: transparent nylon

Element: sintered polypropylene

Elastomers: neoprene and nitrile

F73G & F74G:

Body: aluminum

Transparent bowl: polycarbonate

Transparent with guard: polycarbonate, aluminum guard

Metal bowl: aluminum

Metal bowl liquid level indicator lens: transparent nylon

Element: sintered polypropylene

Elastomers: Neoprene and nitrile



Ordering information

Models listed include PTF threads, automatic drain, metal bowl with liquid level indicator, and a 40 µm element.

Port Size	Model	Flow† scfm (dm3/s)	Weight lb (kg)
1/4"	F72G 2AN AE3	55 (26)	1.15 (0.52)
3/8"	F73G 3AN AD3	65 (31)	1.1 (0.50)
1/2"	F74G 4AN AD3	140 (66)	1.79 (0.81)
3/4"	F74G 6AN AD3	140 (66)	1.75 (0.79)

† Typical flow with a 40µm element at 90 psig (6.3 bar) inlet pressure and 5 psig (0.35 bar) pressure drop.

Options selector

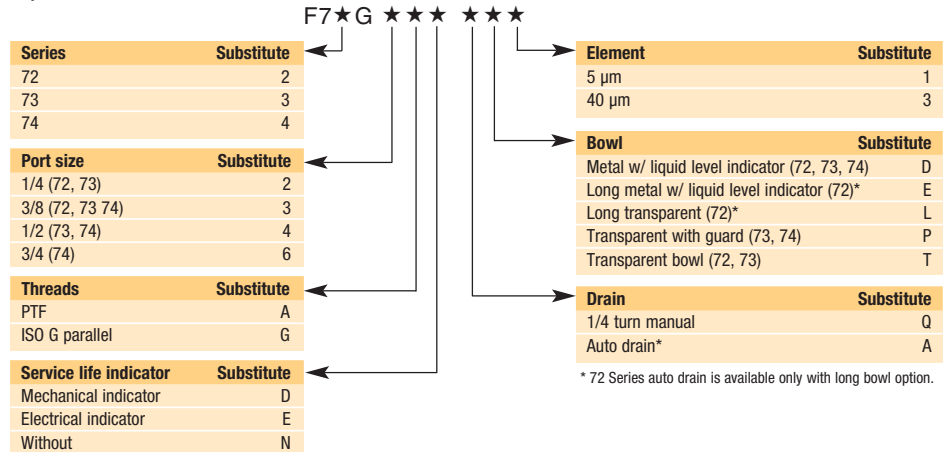

Excelon® Modular System

F72G, F73G, F74G General Purpose Filters

Dimensions in inches

Accessories

	Wall mounting bracket*	Quikmount pipe adapters (quantity of 1) (NPT)	Quikclamp®†	Quikclamp® and wall bracket	Service kit Seal and gasket	Replacement elements
F72G	4224-50	4215-02 (1/4) 4215-03 (3/8)	4214-51	4214-52	4380-500	5925-03 (5µm) 5925-02 (40µm)
F73G	4424-50	4315-01 (1/4) 4315-02 (3/8) 4315-03 (1/2) 4315-04 (3/4)	4314-51	4314-52	4380-600	4438-01 (5µm) 4438-03 (40µm)
F74G	4324-50	4315-02 (3/8) 4315-03 (1/2) 4315-04 (3/4)	4314-51	4314-52	4380-700	4338-04 (5µm) 4338-05 (40µm)

* Bracket kit does not include wall mounting screws.

† Quikclamp is patented (US patent 5372392) and foreign patents.

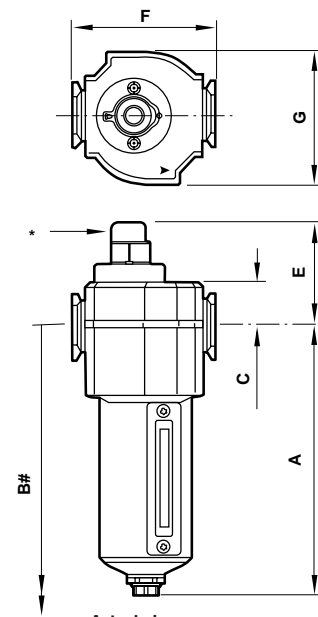

Auto drain

* Optional service indicator

Minimum clearance required to remove bowl

Series	Drain type	A	B	C	E	F	G
72	Auto	5.51	7.52	0.75	2.09	1.97	1.89
	Manual	5.83	7.83	0.75	2.09	1.97	1.89
73	Auto	5.80	8.15	0.98	2.36	2.68	2.44
	Manual	6.15	8.50	0.98	2.36	2.68	2.44
74	Auto	6.35	9.06	0.98	2.36	3.15	2.91
	Manual	6.95	9.69	0.98	2.36	3.15	2.91

Mounting bracket

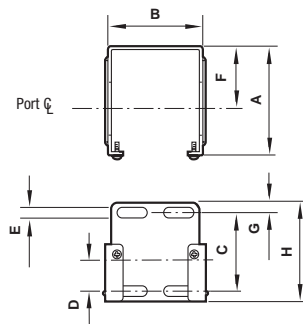

	A	B	C	D	E	F	G	H
72	2.36	1.65	1.54	0.73	0.16	1.50	0.24	2.01
73	2.64	2.36	1.89	0.75	0.28	1.50	0.24	2.40
74	3.11	2.72	1.97	0.79	0.20	2.01	0.24	2.40

F72G FLOW CHARACTERISTICS

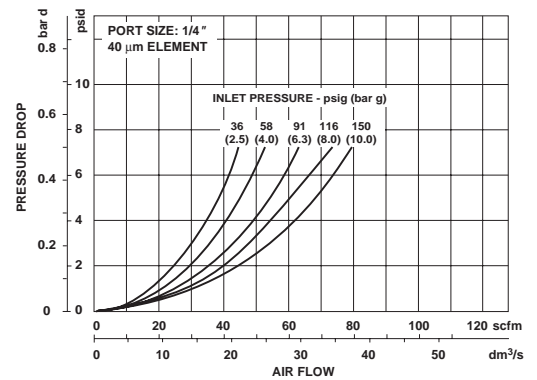

F73G FLOW CHARACTERISTICS

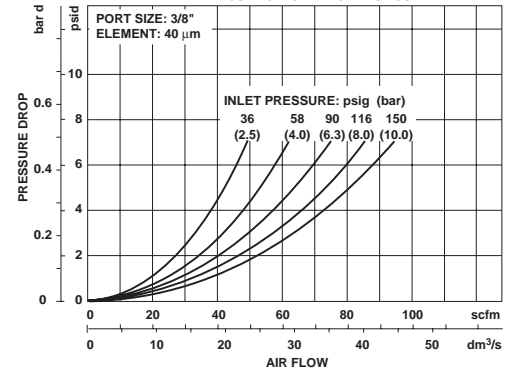

F74G FLOW CHARACTERISTICS

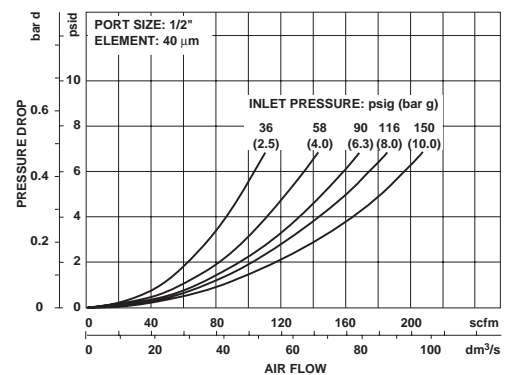

Excelon® Modular System

F72C, F73C, F74C, F74H Oil Removal (Coalescing) Filters

Excelon® design allows in-line or modular installation
High efficiency oil and particle removal
Quick release bayonet bowl
Standard visual service life indicator turns from green to red when the filter element needs to be replaced
Technical data

Fluid:
 Compressed air
Maximum pressure:
 Transparent bowl w/manual drain:
 150 psig (10 bar)
 F72C metal bowl w/auto drain :
 116 psig (8 bar)
 Metal bowl w/manual drain:
 250 psig (17 bar)
 Automatic drain: 116 psig (8 bar)
Operating temperature*:
 Transparent bowl:
 -30° to 125°F (-34° to 50°C)
 Metal bowl:
 -30° to 150°F (-34° to 65°C)

* Air supply must be dry enough to avoid ice formation at temperatures below 35°F (2°C).
 Oil removal: 0.01 µm at 70°F (21°C)
 Remaining oil content: 0.01 mg/m³ at 70°F (21°C)

Materials

F72C
 Body: zinc
 Bowl transparent: polycarbonate
 Metal: zinc
 Metal bowl liquid level indicator lens: Transparent nylon
 Element: synthetic fiber and polyurethane foam
 Elastomers: neoprene and nitrile
 Service life indicator materials-Body: transparent nylon.
 Internal parts: acetal.
 Spring: stainless steel.
 Elastomers: nitrile
F73C and F74C
 Body: aluminum
 Transparent bowl: polycarbonate
 Transparent with guard: polycarbonate,
 Guard: aluminum
 Metal bowl: aluminum
 Metal bowl liquid level indicator lens: Transparent nylon
 Element: synthetic fiber and polyurethane foam
 Elastomers: neoprene and nitrile
 Mechanical service indicator materials
 Body: transparent nylon
 Internal parts: Acetal
 Spring: Stainless steel
 Elastomers: Nitrile



Ordering Information

Models listed include PTF threads, service indicator, automatic drain, and a metal bowl with liquid level indicator.

Port Size	Model Number	Maximum Flow* scfm (dm3/s)	Weight lb (kg)
1/4"	F72C 2AD AEO	9.5 (4.5)	1.2 (0.54)
3/8"	F73C 3AD ADO	21.2 (10.0)	1.2 (0.54)
1/2"	F74C 4AD ADO(std)	33.9 (16.0)	1.84 (0.83)
1/2"	F74H 4AD ADO (hi)	59.3 (28.0)	2.45 (1.11)
3/4"	F74H 6AD ADO (hi)	59.3 (28.0)	2.40 (1.10)

* Maximum flow with 90 psig (6.3 bar) inlet pressure to maintain stated oil removal performance.

Options selector

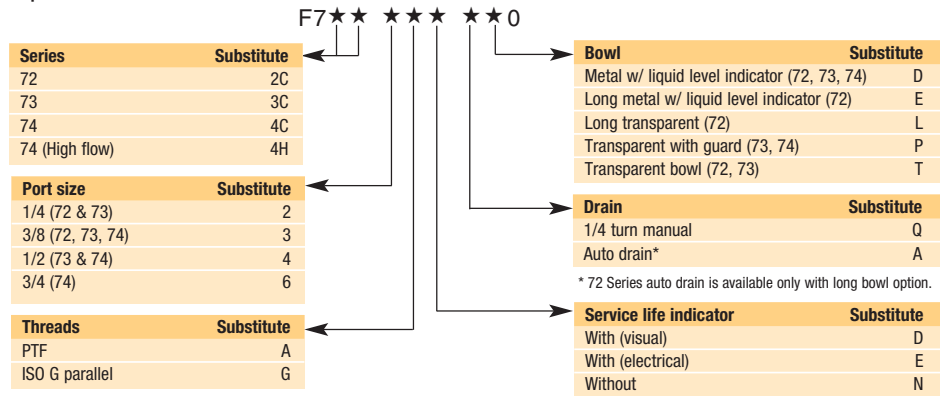

NOTE: Coalescing filters should be used in conjunction with a 5µm general purpose filter upstream to maximize filter element life and optimize performance.

Excelon® Modular System

F72C, F73C, F74C, F74H Oil Removal (Coalescing) Filters

Dimensions in inches.

Accessories

	Wall mounting bracket*	Quikmount pipe adapters (quantity of 1) (NPT)	Quikclamp†	Quikclamp® and wall bracket	Visual service indicator	Electrical service life indicator	Service kit Seal and gasket	Replacement elements
F72C	4224-50	4215-02 (1/4) 4215-03 (3/8)	4214-51	4214-52			4380-500	5925-09
F73C	4424-50	4315-01 (1/4) 4315-02 (3/8) 4315-03 (1/2) 4315-04 (3/4)	4314-51	4314-52	5797-50	4020-51R	4380-602	4444-01
F74C, F74H	4324-50	4315-02 (3/8) 4315-03 (1/2) 4315-04 (3/4)	4314-51	4314-52	5797-50	4020-51R	4380-730 4344-02 (F74H)	4344-01 (F74C)

* Bracket kit does not include wall mounting screws.

† Quikclamp is patented (US patent 5372392) and foreign patents.

Mounting bracket

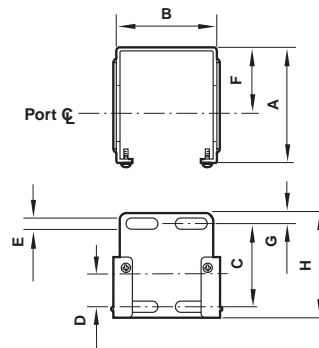
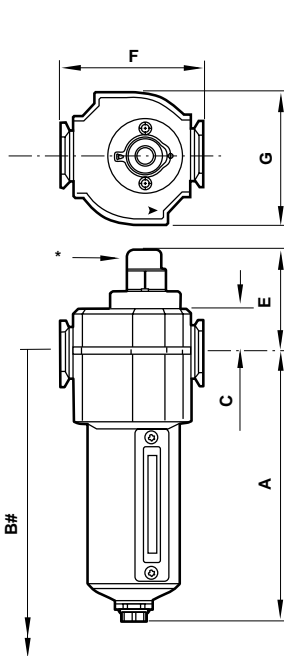

Series	A	B	C	D	E	F	G	H
72	2.36	1.65	1.54	0.73	0.16	1.50	0.24	2.01
73	2.64	2.36	1.89	0.75	0.28	1.50	0.24	2.40
74	3.11	2.72	1.97	0.79	0.20	2.01	0.24	2.40

Series	Drain type	A	B	C	E	F	G
F72C	Auto	5.51	7.52	0.75	2.09	1.97	1.89
	Manual	5.83	7.83	0.75	2.09	1.97	1.89
F73C	Auto	5.80	8.15	0.98	2.36	2.68	2.44
	Manual	6.15	8.50	0.98	2.36	2.68	2.44
F74C	Auto	6.35	9.17	0.98	2.36	3.15	2.91
	Manual	6.95	9.80	0.98	2.36	3.15	2.91
F74H	Auto	8.44	11.18	0.98	2.36	3.15	2.91
	Manual	9.04	11.81	0.98	2.36	3.15	2.91

* Standard service indicator

Minimum clearance required to remove bowl

F72

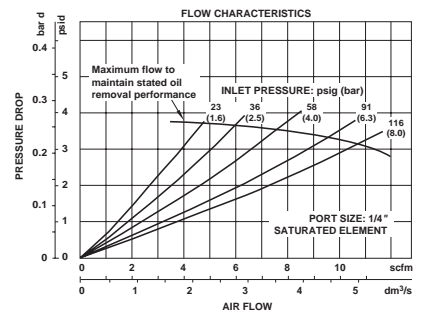

F73

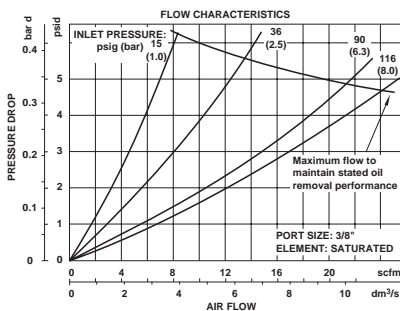

F74C

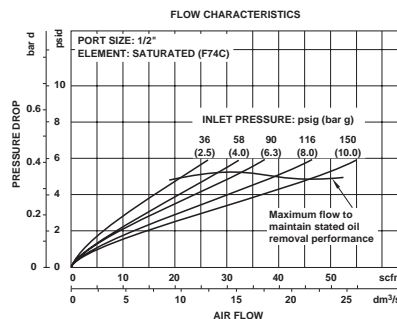

F74H

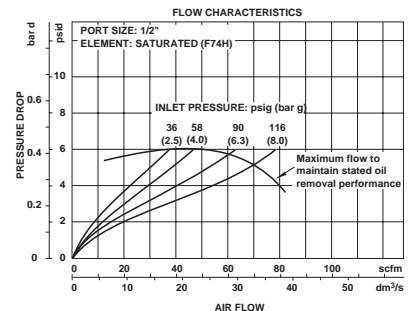

Excelon® Modular System

F72V, and F74V Oil Vapor Removal (adsorbing) Filters

Element color band changes to blue indicating need for replacement.
 Excelon® design allows in-line or modular installation
 Adsorbing type activated carbon element removes oil vapors and most hydrocarbon odors
 Quick release bayonet bowl
 Modular installations with Excelon® 72, 73, and 74 series can be made to suit particular applications



F72V



F74V

Technical data

Fluid:

Compressed air

Maximum pressure:

Transparent bowl: 150 psig (10 bar)

Metal bowl: 250 psig (17 bar)

Operating temperature*:

Transparent bowl:

0° to 125°F (-20° to 50°C)

Metal bowl:

0° to 150°F (-20° to 65°C)

* Air supply must be dry enough to avoid ice formation at temperatures below 35°F (2°C)

Air quality:

Within ISO 8573-1, Class 1 (oil content) when installed downstream of an oil removal filter.

Maximum remaining oil content in outlet air:

0.003 ppm at 70°F (20°C)

Materials

F72V

Body: zinc

Transparent bowl: polycarbonate

Guard for transparent bowl: zinc

Metal bowl: zinc

Element: Activated carbon and polycarbonate

Elastomers: nitrile

F74V

Body: aluminum

Transparent Bowl: polycarbonate with steel bowl guard

Metal bowl: aluminum

Element: activated carbon and aluminum

Elastomers: neoprene and nitrile

Ordering Information

Models listed include PTF threads.

Port Size	Model	Flow* scfm (dm3/s)	Weight lb (kg)
1/4"	F72V 2AN ELC	3.4 (1.6)	0.88 (0.40)
1/2"	F74V 4AN EMA	21 (10)	2.51 (1.14)
3/4"	F74V 6AN EMA	21 (10)	2.46 (1.12)

* Maximum flow with 90 psig (6.3 bar) inlet pressure to maintain stated oil removal performance.

Options selector

F7★V★★N E★★

Series	Substitute	Element	Substitute
72	2	Activated carbon (74)	A
74	4	Activated carbon (72)	C

Port size	Substitute	Bowl	Substitute
1/4 (72)	2	Metal (72)	C
3/8 (72, 74)	3	Long transparent (72)	L
1/2 (74)	4	Metal (74)	M
3/4 (74)	6	Transparent with guard (74)	P

Threads	Substitute
PTF	A
ISO G parallel	G

Oil vapor removal filters must be protected upstream by an oil removal filter and general purpose filter.

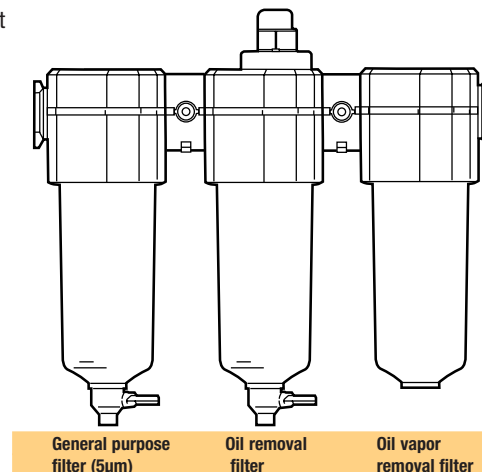

Excelon® Modular System

F72V and F74V Oil Vapor Removal (adsorbing) Filters

Accessories

	Wall mounting bracket*	Quikmount pipe adapters (quantity of 1) (NPT)	Quikclamp®	Quikclamp® and wall bracket	Service kit seal and gasket	Replacement elements
F72V	4224-50	4215-02 (1/4) 4215-03 (3/8)	4214-51	4214-52	4380-500	4241-01
F74V	4324-50	4315-02 (3/8) 4315-03 (1/2) 4315-04 (3/4)	4314-51	4314-52	4380-750	4341-01

* Bracket kit does not include wall mounting screws.

Typical Performance Characteristics

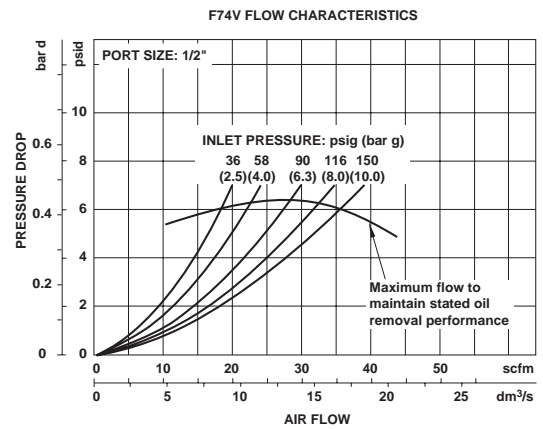
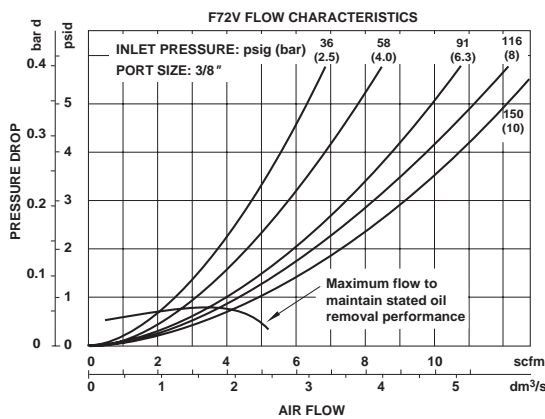

Mounting bracket

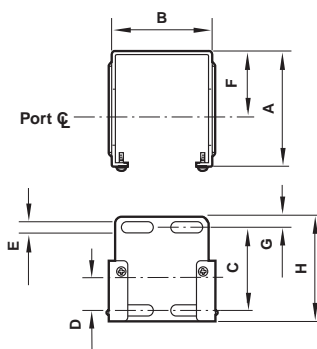

Series	A	B	C	D	E	F	G	H
72	2.36	1.65	1.54	0.73	0.16	1.50	0.24	2.01
74	3.11	2.72	1.97	0.79	0.20	2.01	0.24	2.40

All Dimensions in Inches (mm)

F72V

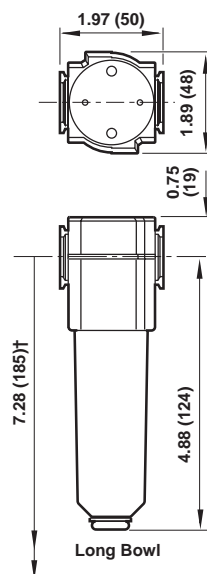

† Minimum clearance required to remove bowl.

F74V

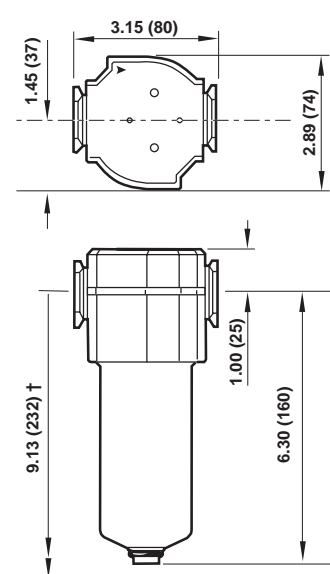

† Minimum clearance required to remove bowl.

Excelon® modular system

B72G, B73G, B74G Filter/Regulators

Excelon® design allows in-line installation or modular installation with other Excelon® products
High efficiency water and particle removal

Quick release bayonet bowl
Push to lock adjusting knob with tamper resistant accessory
Optional patented quarter turn manual drain

Technical data

Fluid:

Compressed air

Maximum pressure:

Transparent bowl: 150 psig (10 bar)

Metal bowl: 250 psig (17 bar)

B72G metal bowl w/ auto drain:
150 psig (10 bar)

Operating temperature*:

Transparent bowl:

-30° to 125°F (-34° to 50°C)

Metal bowl:

(72) -30° to 150°F (-34° to 66°C)

(73, 74) -30° to 175°F (-34° to 80°C)

* Air supply must be dry enough to avoid ice formation at temperatures below 35°F (2°C).

Materials

B72G

Body: zinc

Bonnet: acetal (Zinc on 250 psi model)

Valve: brass

Transparent bowl: polycarbonate

Metal bowl: zinc

Liquid level indicator lens (metal bowl):

transparent nylon

Element: sintered polypropylene

Elastomers: neoprene & nitrile

B73G & B74G:

Body & bonnet: aluminum

Transparent bowl: polycarbonate

Guarded transparent bowl:

polycarbonate with steel

Metal bowl: aluminum

Liquid level indicator lens (metal bowl):

transparent nylon (Pyrex optional)

Element: sintered polypropylene

Elastomers: neoprene & nitrile



Ordering Information

Models listed include PTF threads, knob adjustment, automatic drain, metal bowl with liquid level indicator, 40 µm element, relieving diaphragm, 5 to 150 psig (0.3 to 10 bar) outlet pressure adjustment range* with gauge.

Port Size	Model	Flow† scfm (dm3/s)	Weight lb (kg)
1/4"	B72G 2AK AE3 RMG	80 (38)	1.3 (0.59)
3/8"	B73G 3AK AD3 RMG	123 (58)	1.76 (0.82)
1/2"	B73G 4AK AD3 RMG	123 (58)	1.76 (0.82)
1/2"	B74G 4AK AD3 RMG	212 (100)	2.59 (1.17)
3/4"	B74G 6AK AD3 RMG	212 (100)	2.55 (1.16)

*Outlet pressure can be adjusted to pressures in excess of, and less than, those specified. Do not use these units to control pressures outside of the specified ranges.

† Typical flow with 150 psig (10 bar) inlet pressure, 90 psig (6.3 bar) set pressure and a 15 psig (1 bar) droop from set.

Options selector

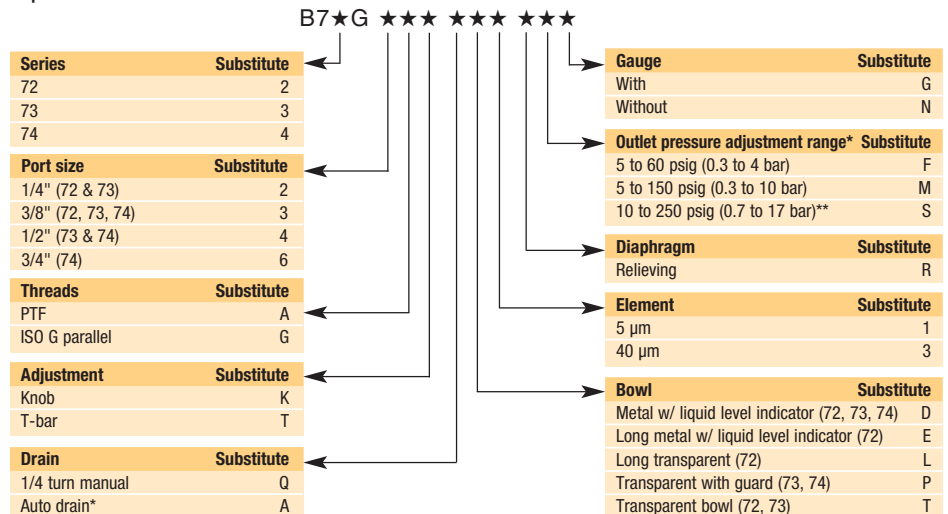

*72 Series auto drain is available only with long bowl option.

*Outlet pressure can be adjusted to pressures in excess of, and less than, those specified. Do not use these units to control pressures outside of the specified ranges.

** 250 psig (17 bar) outlet pressure range units are available with t-handle adjustment only and standard metal bowl options.

Excelon® modular system

B72G, B73G, B74G Filter/Regulators

Dimensions in inches.

Accessories

	Wall mounting bracket*	Neck mounting bracket	Gauge 0 ... 160 psig	Panel nut	Tamper resistant cover and seal wire	Pipe adapters (quantity of 1) (NPT)	Quikclamp®	Quikclamp® and wall bracket	Replacement elements
B72G	4224-50	74316-50	18-013-212	4248-89	4255-51	4215-02 (1/4) 4215-03 (3/8)	4214-51	4214-52	5925-03 (5µm) 5925-02 (40µm)
B73G	4424-50	4461-50	18-013-209	5191-88	4455-51	4315-01 (1/4) 4315-02 (3/8) 4315-03 (1/2) 4315-04 (3/4)	4314-51	4314-52	4438-01 (5µm) 4438-03 (40µm)
B74G	4324-50	4368-51	18-013-209	4348-89	4355-51	4315-02 (3/8) 4315-03 (1/2) 4315-04 (3/4)	4314-51	4314-52	4338-04 (5µm) 4338-05 (40µm)

* Bracket kit does not include wall mounting screws.

Mounting bracket

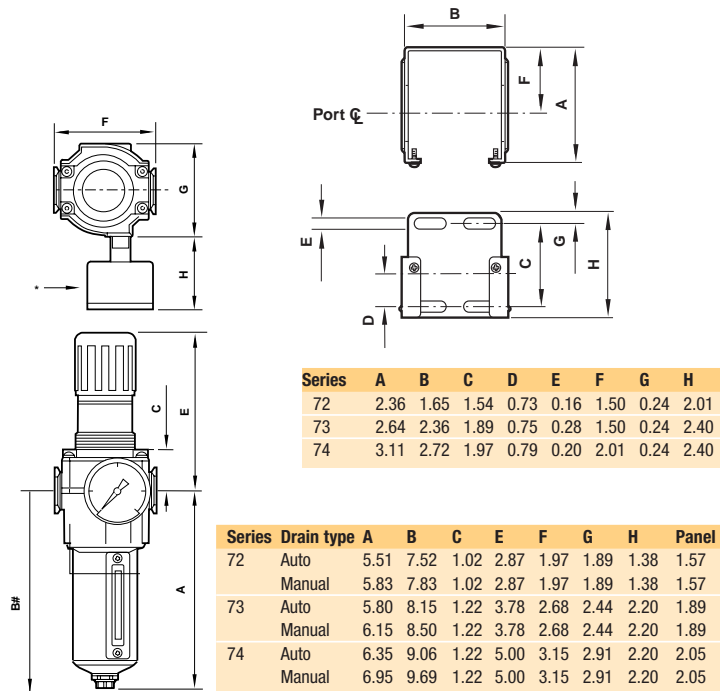

*Optional gauge.

Minimum clearance required to remove bowl.

Neck mounting brackets

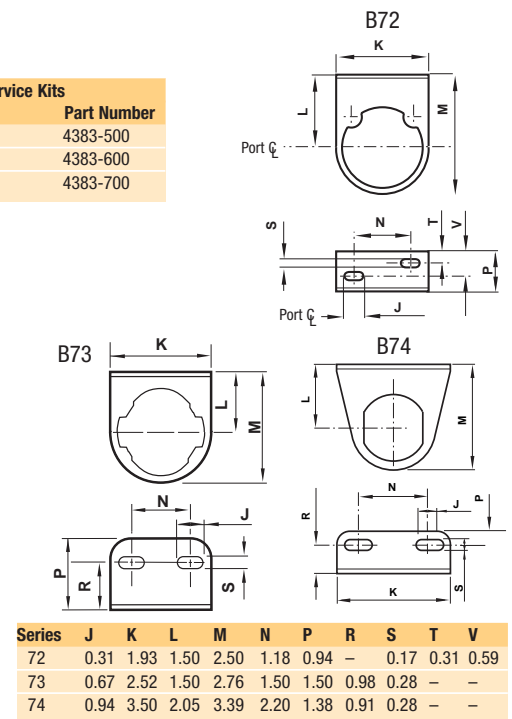

Typical Performance Characteristics

